



broadcastvision
entertainment



Part #: CAB-TRUE-SHOW

The True Showrunner console can now control ANY cable, satellite or IPTV set top box using the CAB (console adapter box) from Broadcastvision Entertainment.



Benefits:

- Eliminates the hand-held battery operated remote control.
- Members can control the TV using cardio equipment console controls.
- An expensive head-end system is not required.
- Club operators can choose ANY cable, satellite or IPTV provider.
- TV channels are not restricted.
- Members can access all the channels available per your subscription.
- No troublesome wireless devices to manage.
- Proven Technology - Broadcastvision first offered a solution for set top box control in 2011 and is the clear-cut market leader in this technology.

BVE Technical Support

Tel: 888.330.4283 x 3 Support@Broadcastvision.com

CAB Configuration

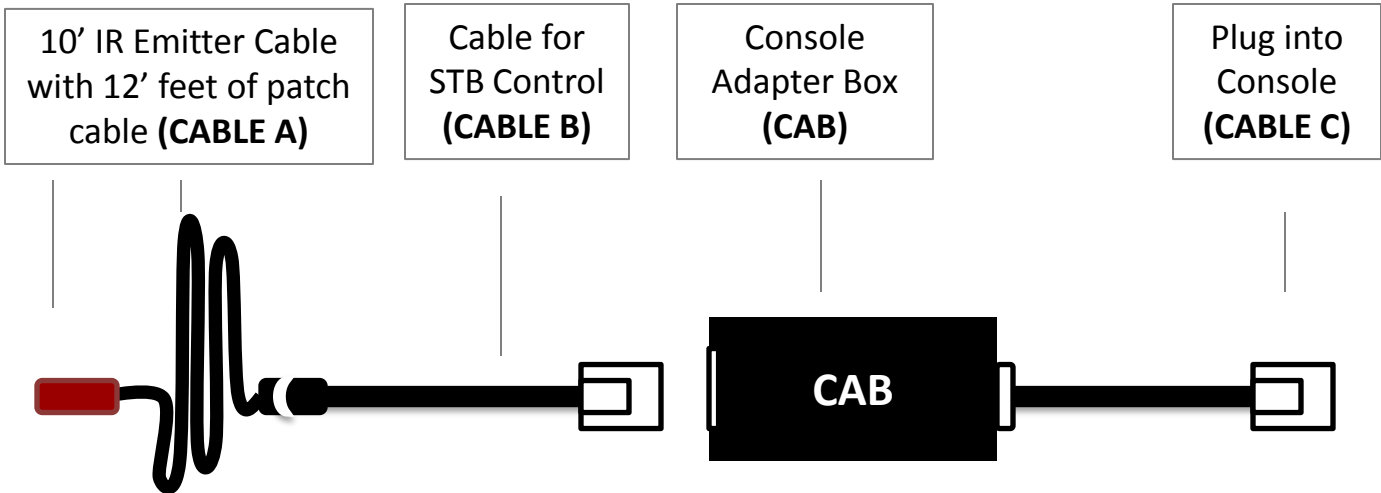

The CAB ships pre-configured by BVE for the target STB at customer facility. Normally no additional configuration steps are required. ***If the CAB does not work for any reason please call technical support at 1(888)330-4283 ext.3 before leaving the facility.*** BVE's technical support staff is happy to help troubleshoot your problems and get the CAB working properly.

The CAB contains 8 dip-switches internally. Normally these should all be in the **OFF position**. To help solve specific deployment compatibility challenges, BVE Technical Support may instruct that some of the switch positions be changed – see the Troubleshooting section at the end of this manual for common settings or call Broadcastvision technical support for additional assistance.

Note: The Broadcastvision CAB should always be installed after the cable/satellite service has already been installed/activated and you have a picture on the screen. If the Set Top Box (STB) is not available at the time of installation you can still run all of the wires and hook up the CAB, but you will not be able to test the CAB to make sure that it is changing channels on the STB.

Installation Instructions

STEP 1 - Perform a TV channel scan. Once in Maintenance Mode, Select **TV SET UP** and then **BEGIN CHANNEL SCAN**. Follow the on-screen prompts to complete the channel scan.

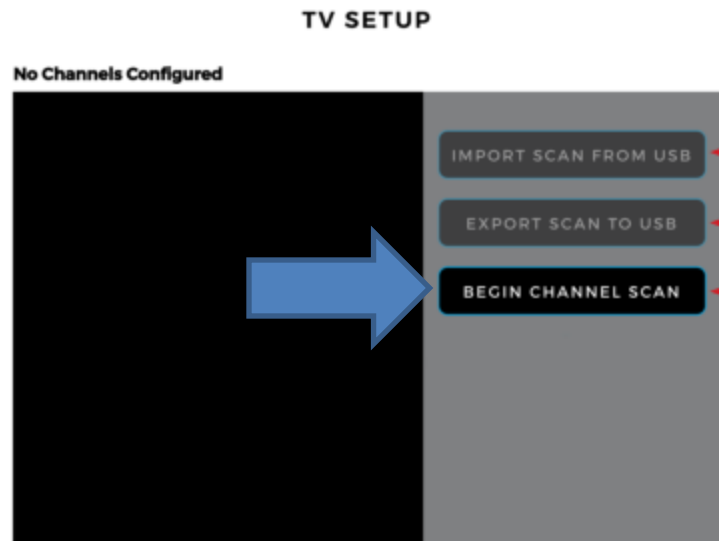

NOTE: If you are having trouble receiving channels after scanning, or having issues with channel clarity after confirming good connections to this machine, please contact your TV provider to ensure proper scan settings and signal strength.

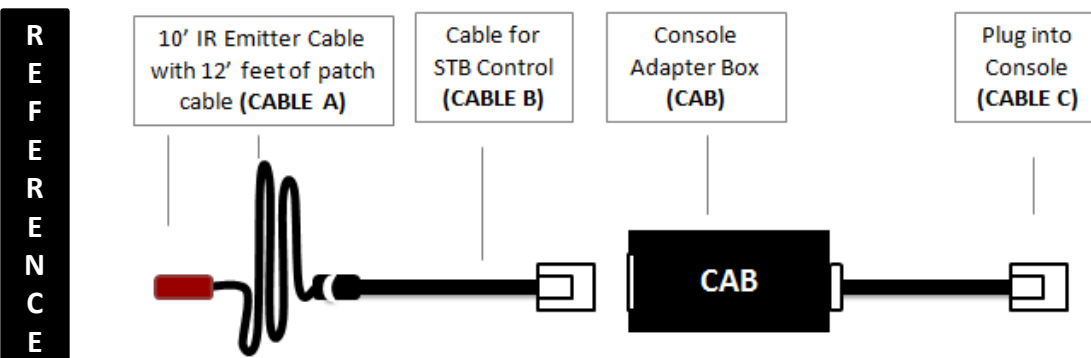

Installation Instructions

STEP 2 – Confirm that Audio and Video is working correctly on the unit.

STEP 3 - Set the channel number on the unit to match the channel number on the cable or satellite box. This is usually channel 3 or 4. Delete the other channels.

STEP 4 - Plug the **CAB (CABLE C)** into the **CSAFE** port on the back of the console.

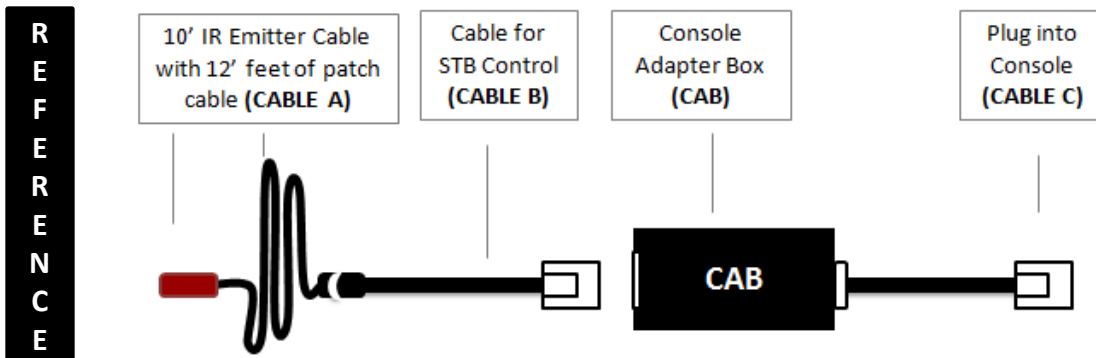

Installation Instructions

STEP 5 – Connect **CABLE A** and **CABLE B** into the CAB. **CABLE A** is a pair of cables that can be used together or separately depending on the length required. The IR cable is 10'. If you need additional length, you can use the coupler provided and the extension cable that is 12' in length.

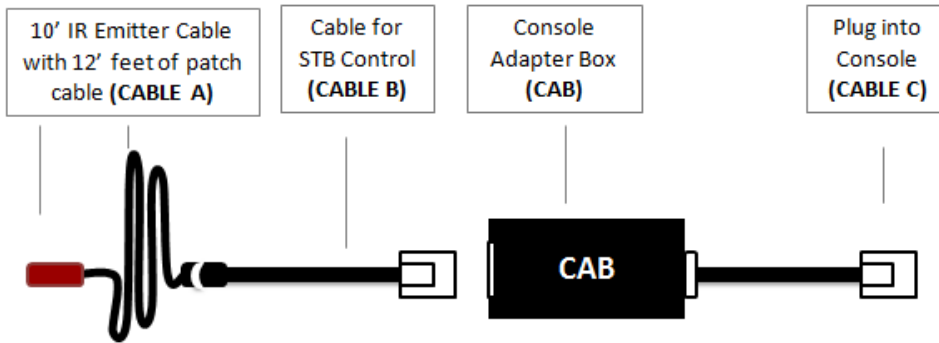

STEP 6 – Secure the CAB (using the double sided velcro) on the outside of the console.

CAB Installation Overview

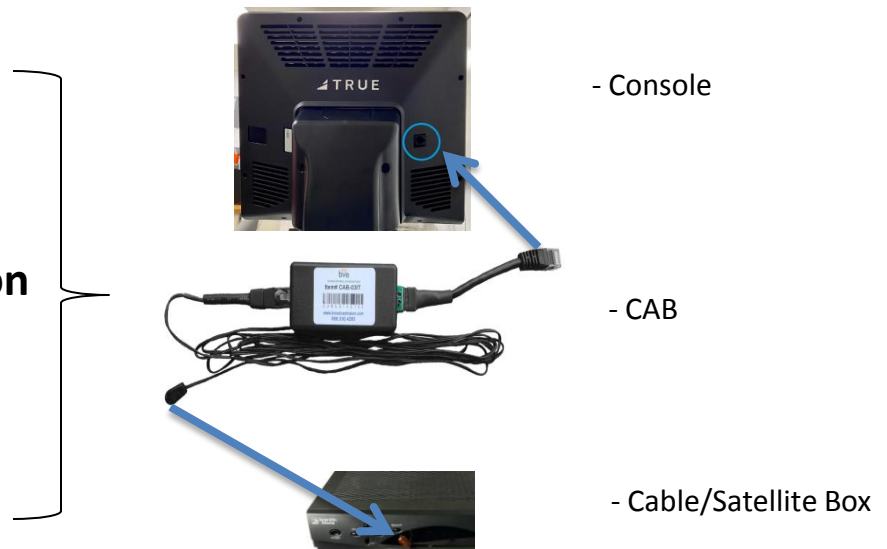

Installation Instructions

STEP 7 – Access the **SET UP MENU** on the True Console from the **MAIN MENU**. Select **CAB SETUP** and follow the instructions.



The image shows a technician menu on the left and a product information screen on the right. The technician menu has two columns of buttons. The left column includes: SUMMARY, SETUP..., OPTIONS, TIMERS, STATISTICS..., and DIAGNOSTICS... The right column includes: PRODUCT SETUP, CALIBRATION, TV SETUP, TV ADVANCED, NETWORK SETUP, SCREEN SAVER, CLOCK, and C.A.B. SETUP. A blue arrow points from the C.A.B. SETUP button to the product information screen. The product information screen displays the following details:

PRODUCT ID	XS1000 ADJUSTABLE STRIDE ELLIP*	
	MODEL #	XS1000
	BASE SERIAL #	20-XS1001234G
	CONSOLE TYPE	SHOWRUNNER
	CONSOLE SERIAL #	
	STRIDE LENGTH RANGE	13.0 TO 30.0 INCHES



Additional Info:

Cable or Satellite box located away from Cardio Equipment.

If the cable or satellite box will be located away from the cardio equipment, you will need to run a cat5/6 cable from each piece of cardio equipment to the cable/satellite box. We offer CAT5/6 adapters that allow you to connect either female or male ends into the CAB for the IR transmission. If you are limited in your cable runs, please contact Mark Blake at 888.330.4283 x 102 for more information.



Troubleshooting

Double button presses – Some set top boxes respond to more than one of the IR codes that we send out. If you notice that pressing a channel button on the console results in multiple presses, simply remove the 2 screws that hold the lid on the CAB and turn on dip switch 2 and 4. If this does not solve the problem, call (888)330-4283 ext.3 for further assistance.

No control over set top box

Check if CAB is getting power and channel commands from the console – CAB contains internal LED power lights. Two indicator LEDs are located on either side of the console-side connector inside the enclosure.

- **GREEN** - Power LED, on whenever the CAB is powered
 - **RED** - Activity LED, flashes whenever the CAB receives and processes commands
- The location of the LEDs is such that they should be visible through the enclosure around the CAB connector to the console.

Incorrect IR emitter placement – If the IR emitter is not in the correct location on the front of the box you may need to move it around until you find the location that works.

Tip: Try initially holding the IR emitter away from the front of the STB initially then continue pressing the channel button while “zeroing in” on the correct IR emitter placement.

Set top box is in RF mode – change to IR mode – Many set top boxes can operate with a hand-held remote in RF or IR mode. For the CAB to function, it is critical that the STB accepts IR channel commands. To test if the STB is in RF mode, place your hand over the hand-held remote control IR transmitter and see if the STB receives channel change commands. If the answer is yes, the STB is in RF mode. Check online for instructions to change the STB remote control mode from RF to IR.

Troubleshooting (continued)

No control over set top box (continued)

IR signal strength issue – In rare circumstances, the CAB may output too strong of an IR signal for the set top box IR receiver. To test if the IR emitter is over-driving the set top box receiver, pull the emitter away from the front of the set top box, and press the channel button to see if the set top box now receives the channel.

No Continuity between CAB and IR emitter – In some circumstances utilizing the “Far” set top box scenario, the CAT5/6 cable between the set top box and the CAB may not provide full continuity through wall plates etc. It may be helpful to re-locate the STB at the base of the cardio and re-test. Or, it may be helpful to temporarily run an alternate CAT5/6 cable from the CAB to the set top box then re-test.

CAB not programmed for the correct set top box - Your CAB is defaulted for Broadcastvision’s popular “Unicode” setting which provides control of the most popular cable, satellite and IPTV set top boxes.

The CAB can be quickly configured on site to operate other popular set top boxes by flipping dip switches inside the CAB enclosure as pictured below. All CABs are shipped pre-programmed what we call unicode. Unicode works with most of the well known providers. If for some reason the CAB is not operational, please call Broadcastvision support at **888.330.4283 x 3** to determine the dip switch settings for your cable, satellite, or IPTV provider.

Note: When the CAB is shipped pre-programmed, the dipswitch setting will be in the OFF position.

